

# DLx PULLING WINCHES



Model #DLx1900FC



U.S. Patents 10640343,  
D867713 and D867714

**DLx1500FC**

**DLx1900FC**

**DLx2600FC**



A Dependable Company Since 1886  
**DUTTON-LAINSON COMPANY**  
Hastings, NE 68902 U.S.A • Tel 402-462-4141 • Fax 402-460-4612  
E-mail [dlsales@dutton-lainson.com](mailto:dlsales@dutton-lainson.com) • Web Site [www.dutton-lainson.com](http://www.dutton-lainson.com)

**MADE IN  
USA**

**ISO 9001 Certified Q.M.S.**

**⚠ WARNING** READ INSTRUCTIONS CAREFULLY BEFORE ATTEMPTING TO INSTALL, OPERATE OR SERVICE THIS WINCH. FAILURE TO COMPLY WITH INSTRUCTIONS COULD RESULT IN SERIOUS OR FATAL INJURY. RETAIN THESE INSTRUCTIONS FOR FUTURE REFERENCE.



## IMPORTANT SAFETY INFORMATION

- This winch is built for multi-purpose hauling and pulling operations. It is not recommended for lifting applications. For lifting, use a self-locking winch. DLx winches are not to be used as hoists for lifting, supporting or transporting people or for loads over areas where people could be present.
- Respect this winch. High forces are created when using a winch, creating potential safety hazards. It should be operated and maintained in accordance with instructions. Never allow children or anyone who is not familiar with the operation of the winch to use it.
- Maintain a firm grip on the winch handle at all times, and never release the handle when ratchet lever is in unlocked position with a load on the winch. Otherwise, handle will spin violently, which could cause personal injury.
- Check for proper ratchet operation on each use of the winch. Do not use if damaged. Seek immediate repairs.
- Never use the winch handle as a convenient handle for pulling or maneuvering the entire trailer or other equipment. Never pull on the winch handle against a locked ratchet.
- Never exceed rated capacity. Excess load may cause premature failure and could result in serious personal injury. This winch is rated with three layers of line on the hub. Using more layers of line or a large hub increases the load on the winch.
- Never apply load on winch with strap or cable extended. Keep at least three full turns of strap or cable on the reel.
- Secure load properly. When winching operation is complete, do not depend on winch to support load.
- Operate with hand power only. This winch should not be operated with a motor of any kind. If the winch cannot be cranked easily with one hand, it is probably over-loaded.

## WINCH MOUNTING AND CABLE ATTACHMENT

For maximum strength and safety, (and compliance with SAE Standard J1853) this winch should be mounted with three 3/8" or M10 bolts, washers, and lock washers. (Use grade 5 or 8 for DLx2600FC). See parts drawing.

Select a winch line with breaking strength at least 1-1/2 times the winch rating and a hook 1-1/2 times stronger than the line. If steel cable is selected, the optional reel with large hub may extend cable life. (The above combination meets SAE Standard J1853 for boat trailer winches).

Attach cable or rope by either method described in sketch. If nylon strap is used, it should have a loop sewn in one end and be attached using a 3/8" x 3" long bolt and locknut. Use a locknut, not a nut and lock washer. Insert bolt through slots in both reel side plates so that nut is on gear side. Tighten only until snug with bolt in bottom of slot next to reel hub.

To mount the winch, the top cover will need to be removed from the winch. To install cable or strap, the top cover and sides will need to be removed. See winch cover removal and assembly section for instructions.

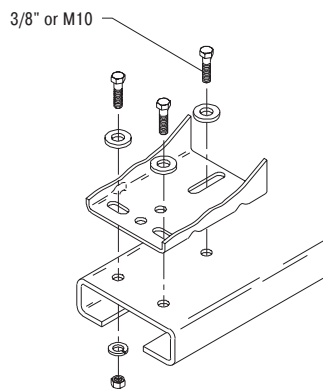

## WINCH MAINTENANCE

This winch has been fully lubricated at the factory; but, for continued smooth performance and increased life, occasional greasing of gears and reel shaft and an occasional drop of oil on drive shaft bearings are recommended. Keep winch in good working order. Damaged or severely-worn parts create unnecessary dangers and could result in personal injury or property damage.

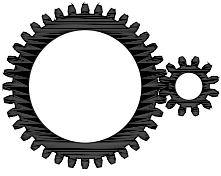

DLx1500FC – 4.4:1  
 DLx1900FC – 5.4:1  
 DLx2600FC – 17.3:1/5.4:1

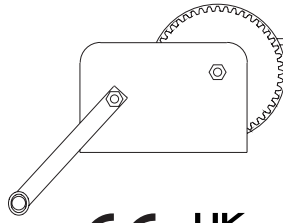

DLx1500FC – 1500 lbs/680 kg  
 DLx1900FC – 1900 lbs/862 kg  
 DLx2600FC – 2600 lbs/1179 kg

**CABLE**

DLx1500FC – 1/4" x 40 ft (31 ft strap)  
 DLx1900FC – 9/32" x 49 ft (38 ft strap)  
 DLx2600FC – 5/16" x 47 ft (38 ft strap)

**ENGLISH – DECLARATION OF CONFORMITY**

- Dutton-Lainson Company, Hastings, NE 68902-0729 U.S.A. manufactures and declares that the winch identified above fulfills all relevant provisions of the Directive 2006/42/EC, and Supply of Machinery (Safety) Regulations 2008. The technical file may be obtained from the persons listed below.

**DEUTSCH – KONFORMITÄTSERKLÄRUNG**

- Dutton-Lainson Company, Hastings, NE 68902-0729, USA, der Hersteller der Winde, erklärt, dass die oben angegebene Winde alle relevanten Bestimmungen der Richtlinie 2006/42/EG erfüllt. Die technischen Unterlagen sind bei den nachfolgend aufgeführten Personen erhältlich.

**FRANÇAIS – DÉCLARATION DE CONFORMITÉ**

- Dutton-Lainson Company, Hastings, NE 68902-0729 U.S.A. construit le treuil mentionné ci-dessus et déclare qu'il répond à toutes les dispositions applicables de la Directive 2006/42/CE. Le dossier technique peut être obtenu auprès des personnes indiquées ci-dessous.

**ESPAÑOL – DECLARACION DE HOMOLOGACION**

- Dutton-Lainson Company, de Hastings, NE 68902-0729 EE.UU., fabrica y declara que el cabrestante arriba identificado satisface todas las provisiones pertinentes de la directriz 2006/42/EC. El archivo técnico puede obtenerse de las personas mencionadas a continuación.

Hastings, NE USA  
 March 21, 2022

Director of Engineering  
 Dutton-Lainson Company

Jack Singleton  
 Eurowarehouse BV  
 De Amstel 11  
 8253PC Dronten  
 The Netherlands

**ENGLISH** -To obtain a copy of the warranty in English, send a self-addressed envelope to: Dutton-Lainson Company; P.O. Box 729; Hastings NE 68902-0729; U.S.A.

**DEUTSCH** - Wenn Sie eine deutsche Kopie der Garantibestimmungen erhalten möchten, senden Sie bitte einen adressierten Rückumschlag an: Dutton-Lainson Company; P.O.Box 729; Hastings NE 68902-0729; USA

**FRANÇAIS** - Pour obtenir une copie de la garantie en français, envoyer une enveloppe à votre nom et adresse à : Dutton-Lainson Company; P.O. Box 729; Hastings NE 68902-0729; U.S.A.

**ESPAÑOL** - Para obtener una copia de la garantía en español, envíe un sobre con su dirección impresa a: Dutton-Lainson Company, P.O. Box 729; Hastings NE 68902-0729 EE.UU.

## OPERATING INSTRUCTIONS DLx1500FC & DLx1900FC

HANDLE AND NUT MUST BE TIGHTENED AGAINST DRIVE SHAFT BEFORE OPERATING WINCH. Wind line on winch reel by turning winch handle in clockwise direction with ratchet lever in up position. The ratchet should produce a loud, sharp clicking noise. Make sure that ratchet lever is in up position and holding load before winch handle is released. To unwind or reel out line, securely grip winch handle and apply force in clockwise direction so that ratchet lever can easily be moved to down position. Carefully turn handle in counterclockwise direction. Do not lose control. The winch can be converted to wind line on to the underside of the reel. To do this, carefully examine ratchet assembly and remove it from winch. Do not lose small parts. Turn the lever over and reassemble. Do not over tighten bolt. Check operation to insure the ratchet lever rotates fully without binding.

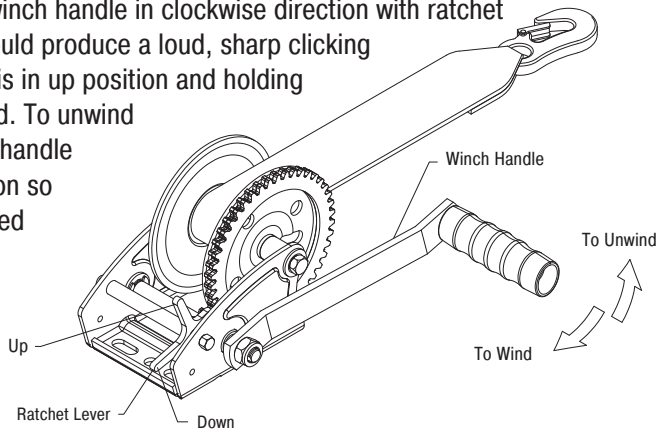

## OPERATING INSTRUCTIONS DLx2600FC

Attach winch handle securely to primary drive shaft (upper or low speed shaft). Make sure that handle clip engages with groove in drive shaft. Wind line on winch reel by turning winch handle in counter clockwise direction with ratchet lever in "down" position. The ratchet should produce a loud, sharp, clicking noise. Make sure that ratchet lever is in "down" position and holding load before winch handle is released. To unwind or reel out line, securely grip winch handle and apply force in counterclockwise direction so that ratchet lever can easily be moved to "up" position. Carefully turn handle in clockwise direction. Do not lose control. If handle is attached to intermediate (lower or high speed) shaft, operate as described above, reversing clockwise and counterclockwise. The winch can be converted to wind line on to the underside of the reel. To do this, carefully examine ratchet assembly and remove it from winch. Do not lose small parts. Turn the lever over and reassemble. Do not over tighten bolt. Check operation to insure the ratchet lever rotates fully without binding.

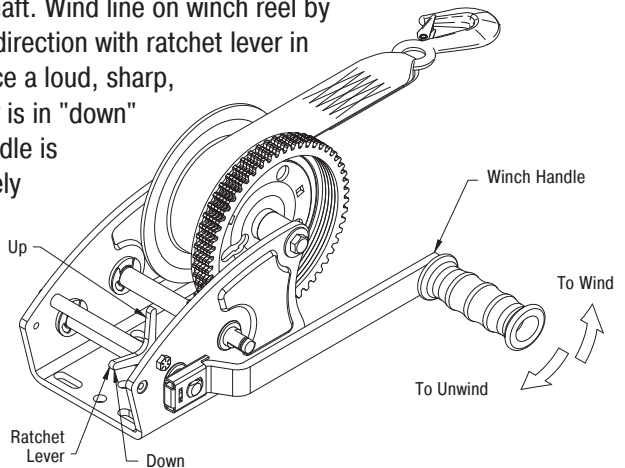

**NOT FOR THE MOVEMENT OF HUMAN BEINGS**

## MAXIMUM STRAP ANGLE

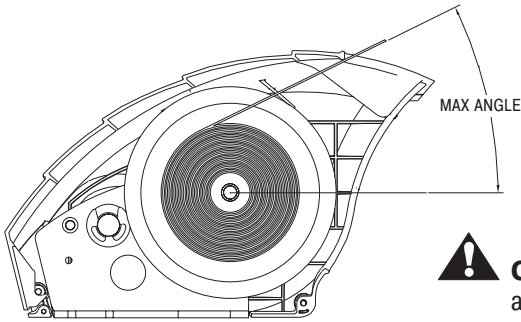

DLx1500FC - 20 Ft. (6.1m) - 25°

DLx1900FC - 20 Ft. (6.1m) - 26°

DLx2600FC - 25 Ft. (7.6m) - 26°



**CAUTION:** Exceeding the maximum strap angle could result in damage to winch cover.

## WINCH COVER REMOVAL AND ASSEMBLY

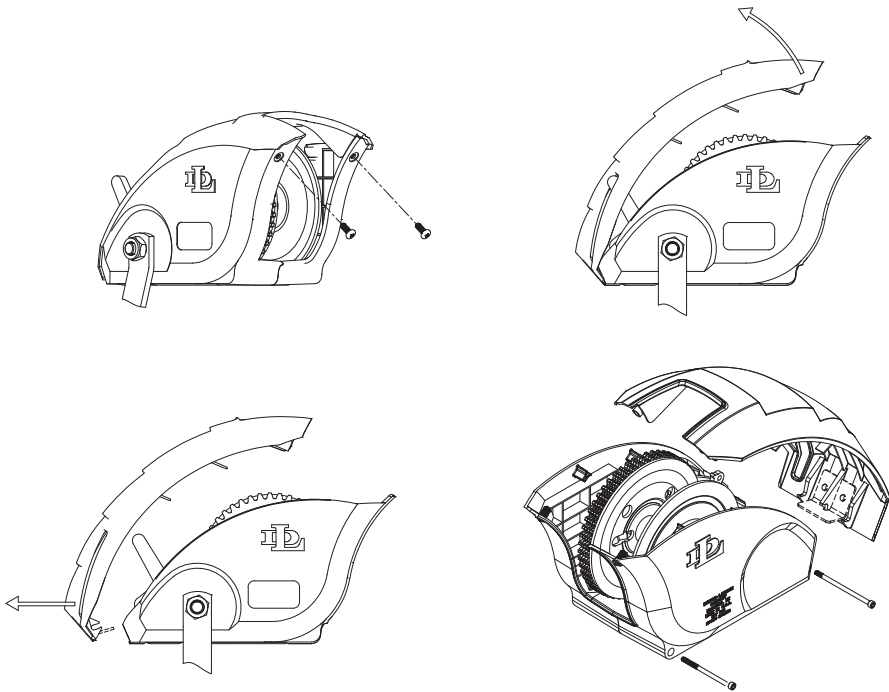

The cover comes off the winch in three pieces. To remove the top cover, loosen and remove the top phillips screws in the front of the cover with a screwdriver. Pull up on the front of the top cover and rotate the top away from the winch. Once the locking tabs are disengaged from the sides, pull the cover straight back to remove.

To remove the cover sides, use a 9/64 hex key to remove the two socket head screws in the bottom front and back on the winch side. Once the screws are removed, pull the cover sides away from the winch to remove.

To reassemble the winch cover, slide the two sides into place around the winch. Use a 9/64 hex key to install the two socket head screws.



**CAUTION:** Tighten cover screws by hand only. Over-tightening could make top cover difficult to install or damage winch cover.

With the sides in place and bolts installed, place the tabs on the back of the top cover around the bolt on the back of the winch. Rotate the top cover back onto the winch and press on the middle of the top until the locking tabs snap into the cover sides. Install the phillips screws in the front of the cover and tighten.



# DLx1500FC

To order replacement parts:

**Dutton-Lainson Company**

www.dlco.com

Tel: 800-569-6577

Fax: 402-460-4612

email: DLsales@dutton-lainson.com

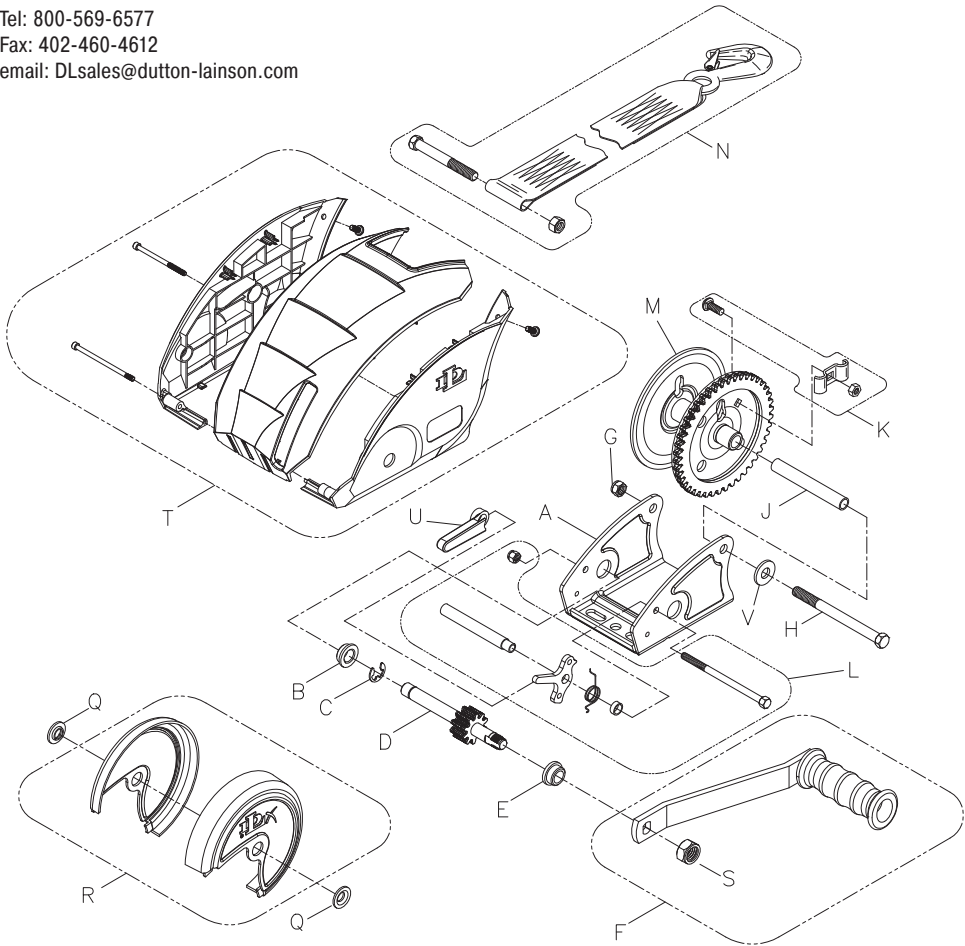

| Ref. | Description                   | Part. No. | Ref. | Description              | Part. No. |
|------|-------------------------------|-----------|------|--------------------------|-----------|
| A    | Base - DLx1500                | 406195    | L    | Ratchet Kit              | 5704556   |
| B    | Bushing                       | 204006    | M    | Reel - DLx1500           | 306278    |
| C    | Retaining Ring                | 205012    | N    | Strap, 20 ft.            | 5242607   |
| D    | Drive Shaft                   | 304722    | Q    | Spacer Washer            | 404916    |
| E    | Bushing                       | 204007    | R    | Reel Cover Kit           | 5170030   |
| F    | DLx1500 Handle 9-1/2" - Black | 5703855   | S    | Nut                      | 205015    |
| G    | Locknut                       | 205270    | T    | Full Cover Kit - DLX1500 | 5170295   |
| H    | Reel Bolt                     | 203161    | U    | Ratchet Pawl Cover       | 206766    |
| J    | Reel Spacer                   | 204807    | V    | Washer                   | 205044    |
| K    | Rope Clamp Kit (Opt.)         | 5243506   |      |                          |           |



# DLx1900FC

To order replacement parts:

## Dutton-Lainson Company

www.dlco.com

Tel: 800-569-6577

Fax: 402-460-4612

email: DLsales@dutton-lainson.com

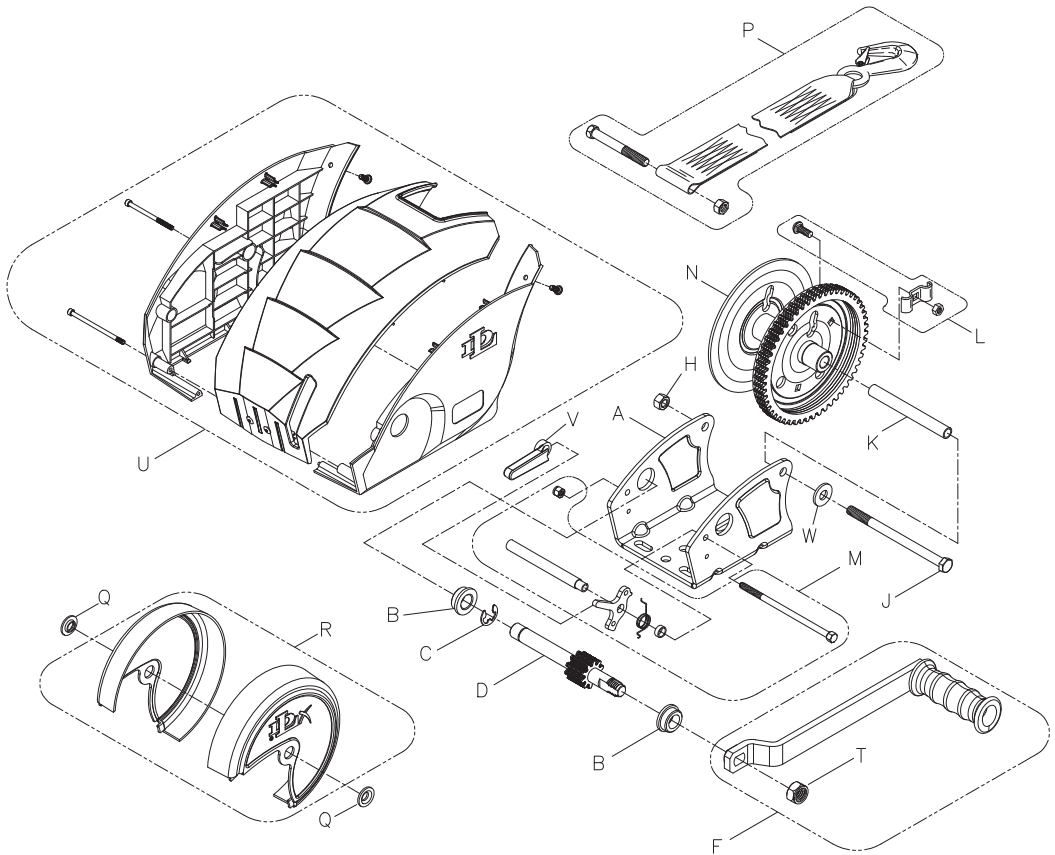

| Ref. | Description           | Part. No. | Ref. | Description        | Part. No. |
|------|-----------------------|-----------|------|--------------------|-----------|
| A    | Base                  | 406191    | N    | Reel               | 304779-PL |
| B    | Bushing               | 204009    | N    | Large Hub Reel     | 306124    |
| C    | Retaining Ring        | 205116    | P    | Strap, 20 Ft.      | 5242409   |
| D    | Drive Shaft           | 304731    | Q    | Spacer Washer      | 404916    |
| F    | Handle 9-1/2" Black   | 5703863   | R    | Gear Cover Kit     | 5170451   |
| H    | Locknut               | 205270    | T    | Nut                | 204809    |
| J    | Reel Bolt             | 204804    | U    | Full Cover Kit     | 5170477   |
| K    | Spacer                | 204808    | V    | Ratchet Pawl Cover | 206766    |
| L    | Rope Clamp Kit (Opt.) | 5243506   | W    | Washer             | 205044    |
| M    | Ratchet Kit           | 5704754   |      |                    |           |







# DLx2600FC

To order replacement parts:

## Dutton-Lainson Company

www.dlco.com

Tel: 800-569-6577

Fax: 402-460-4612

email: DLsales@dutton-lainson.com

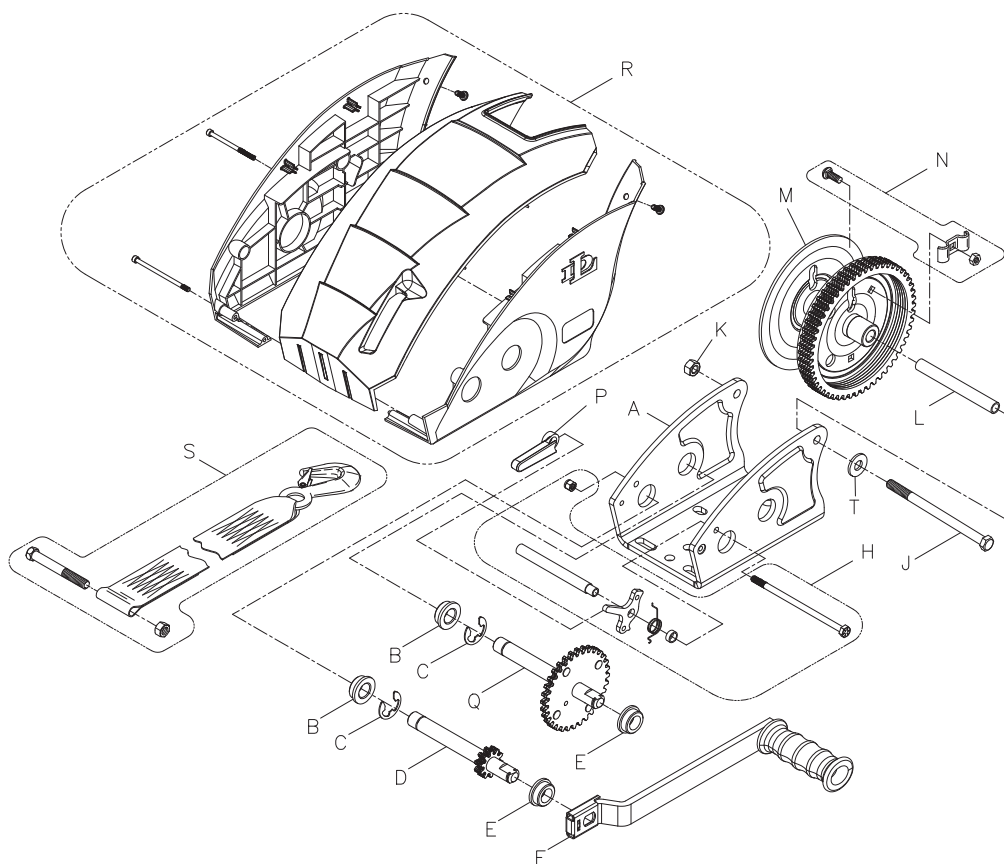

| Ref. | Description           | Part. No.  | Ref. | Description              | Part. No. |
|------|-----------------------|------------|------|--------------------------|-----------|
| A    | Base                  | 406220     | L    | Reel Spacer              | 204808    |
| B    | Bushing               | 204009     | M    | Reel                     | 304782-PL |
| C    | Retaining Ring        | 205116     | N    | Rope Clamp Kit           | 5243506   |
| D    | Primary Shaft         | 304726     | P    | Ratchet Pawl Cover       | 206766    |
| E    | Bushing               | 204012     | Q    | Intermediate Drive Shaft | 304727    |
| F    | Handle 9-1/2" - Black | 306322-BPL | R    | Full Cover Kit           | 5170873   |
| H    | Ratchet Kit           | 5704754    | S    | Strap, 25 Ft.            | 5242482   |
| J    | Reel Bolt             | 204804     | T    | Washer                   | 205044    |
| K    | Lock Nut              | 204803     |      |                          |           |