

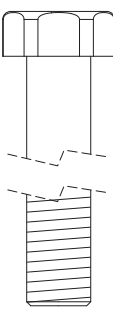
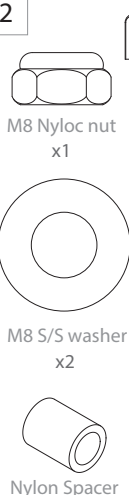
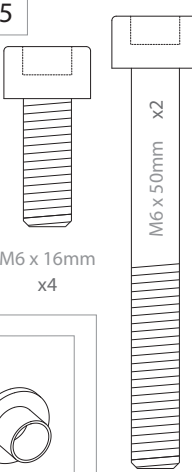
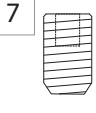
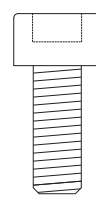

Scanstrut Backstay Self-Levelling Mount Installation Instructions

LMB-A1 / LMB-A2

Issue 7

Tools Required

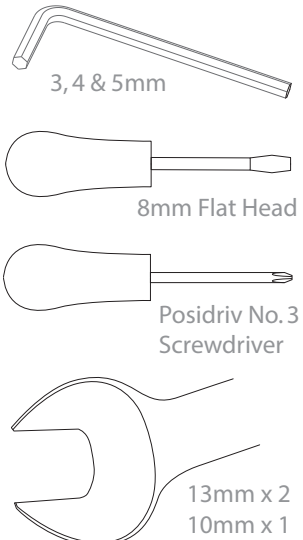
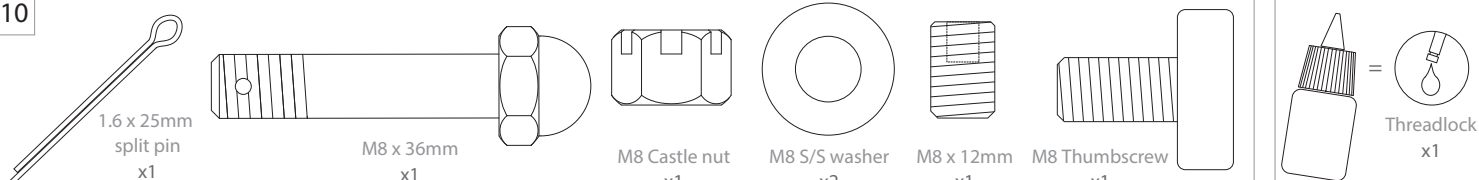
<p>1</p>  <p>M8 x (?)mm x2 (Not Supplied)</p>	<p>2</p>  <p>M8 Nyloc nut x1 M8 S/S washer x2 Nylon Spacer x1</p>	<p>5</p>  <p>M6 x 16mm x4 M6 x 50mm x2</p>	<p>7</p>  <p>M6 x 10mm x2</p>	<p>8</p>  <p>M6 x 16mm x8</p>	<p>9</p>  <p>M6 x 20mm x4 60065 6mm S/S Washer x4 60066 M6 Spring Washer S/S x4 60060 - M6 S/S Nyloc Nut x4</p>	 <p>3, 4 & 5mm 8mm Flat Head Posidriv No. 3 Screwdriver 13mm x 2 10mm x 1</p>
<p>10</p>  <p>1.6 x 25mm split pin x1 M8 x 36mm x1 M8 Castle nut x1 M8 S/S washer x2 M8 x 12mm x1 M8 Thumbscrew x1 Threadlock x1</p>						

A

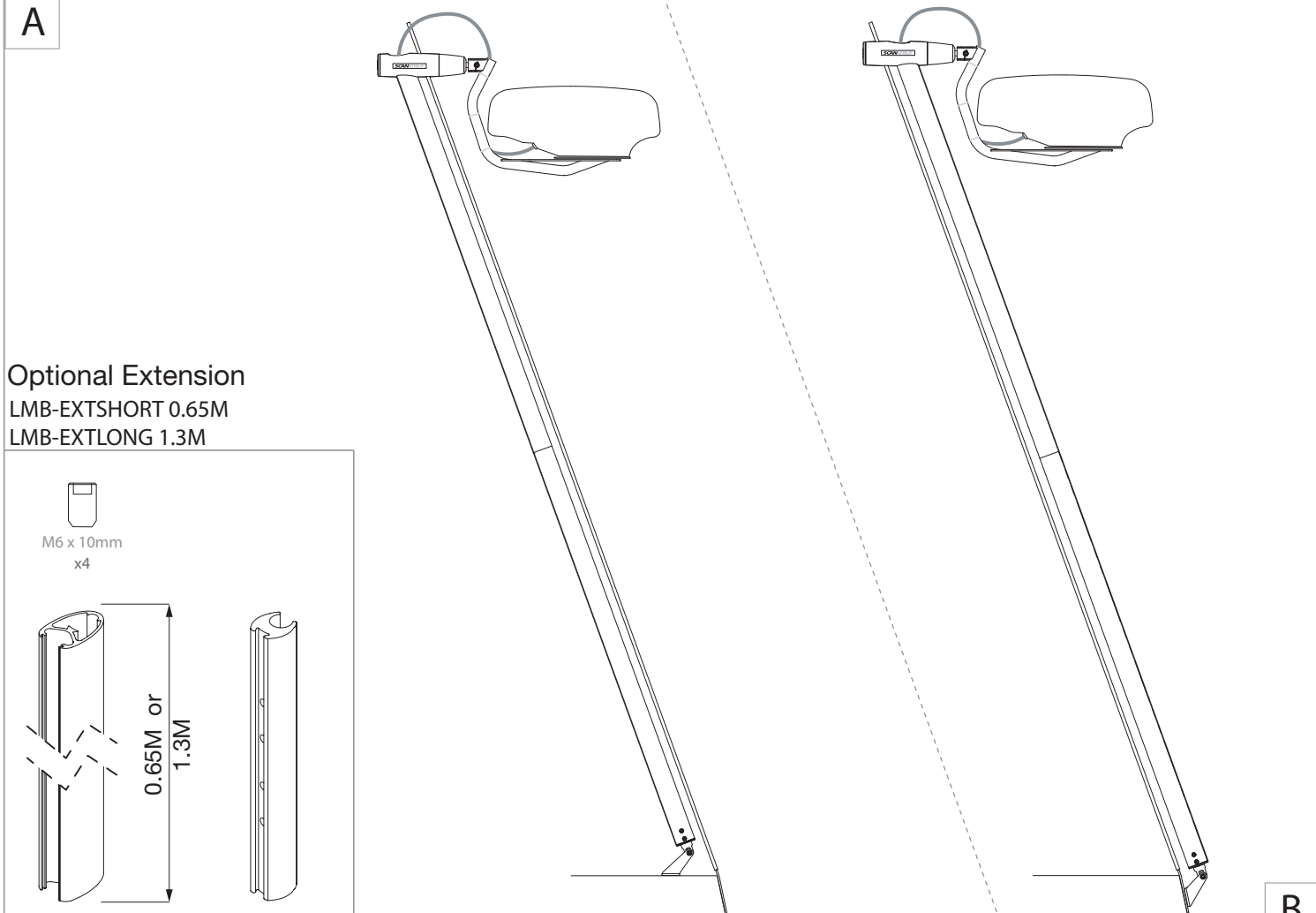

Optional Extension
LMB-EXTSHORT 0.65M
LMB-EXTLONG 1.3M

M6 x 10mm x4

0.65M or 1.3M

B

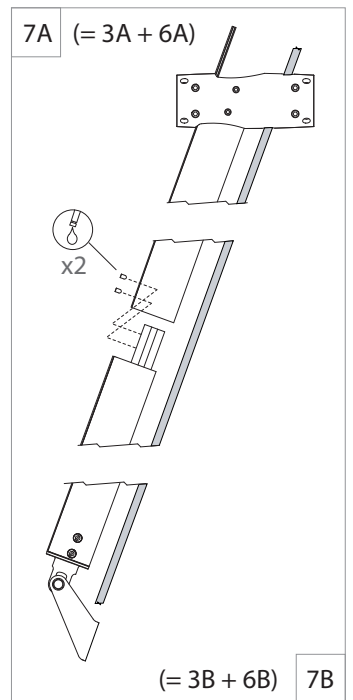
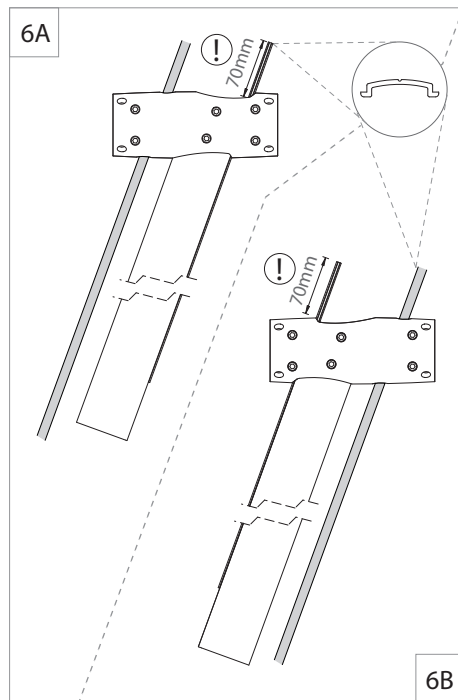
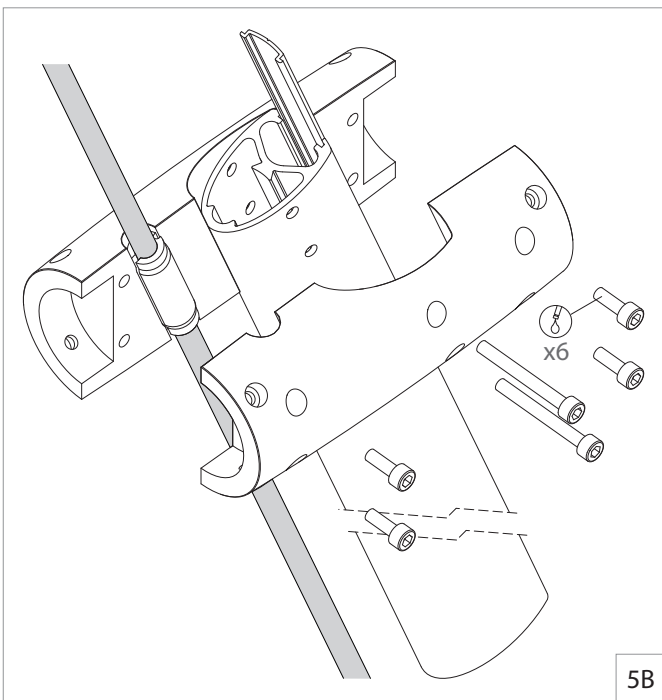
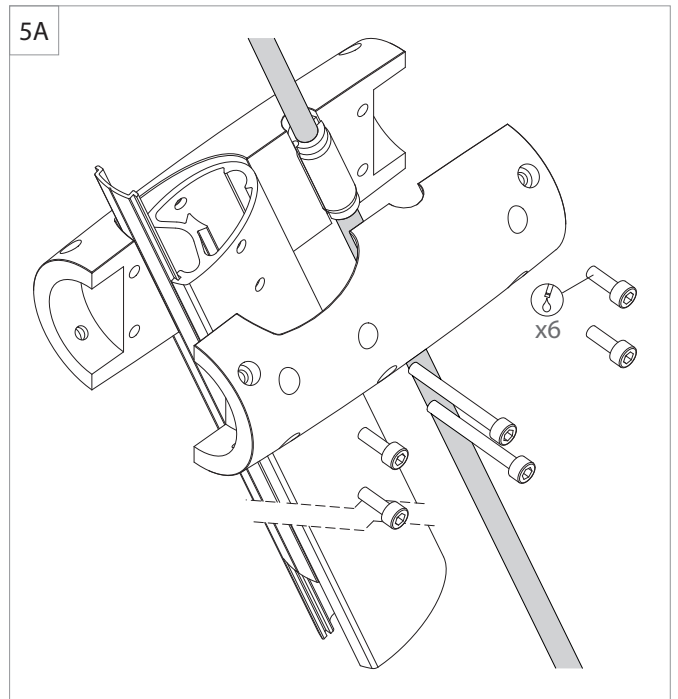
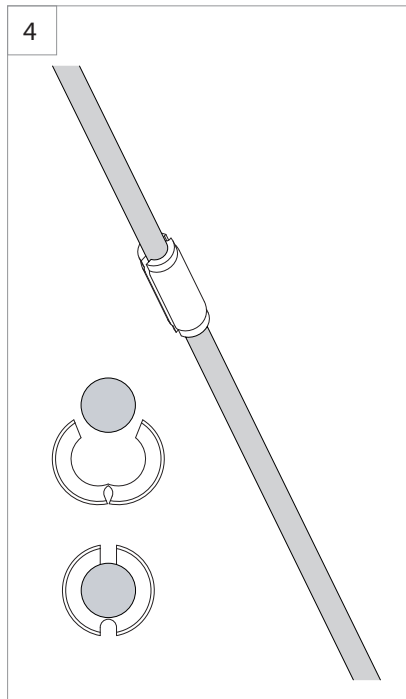
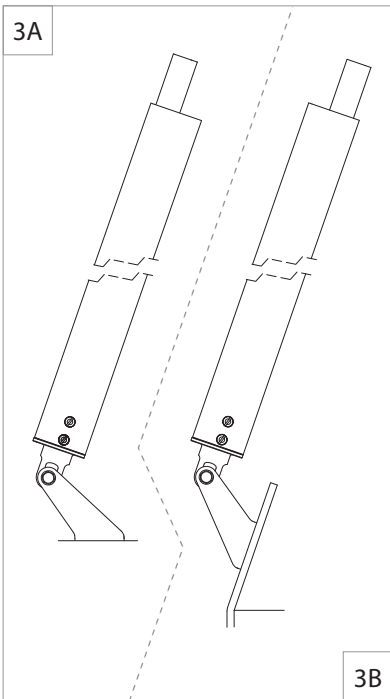
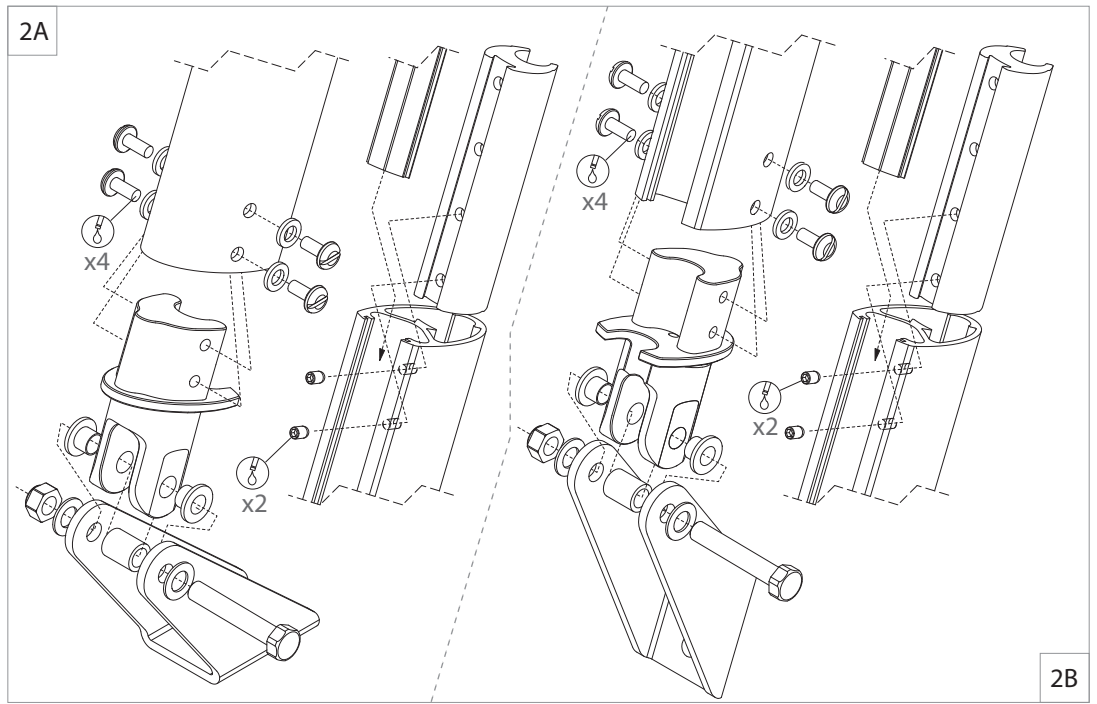
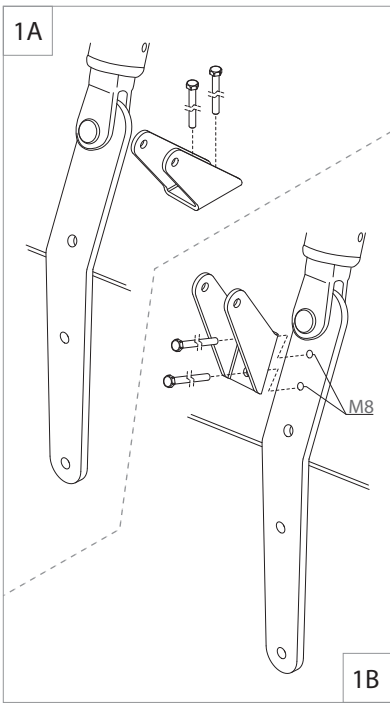

8A

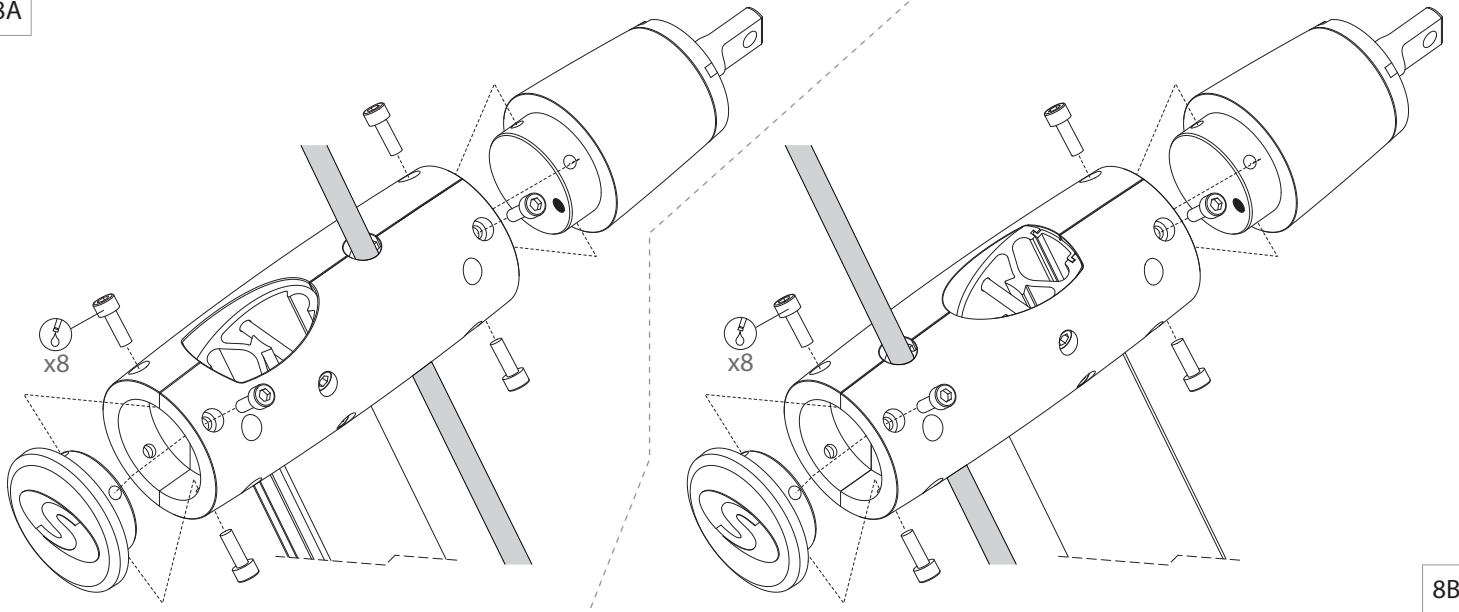

8B

9

Offset mounting holes
for Raymarine domes

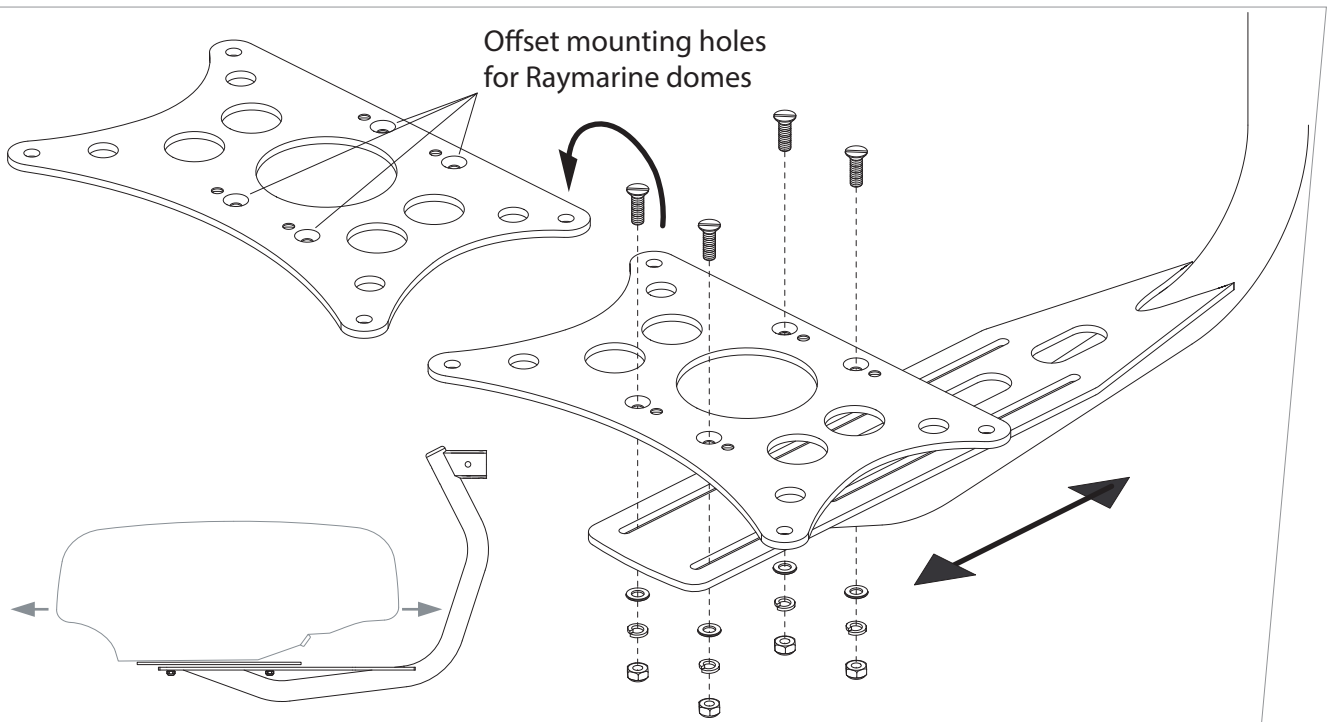

10

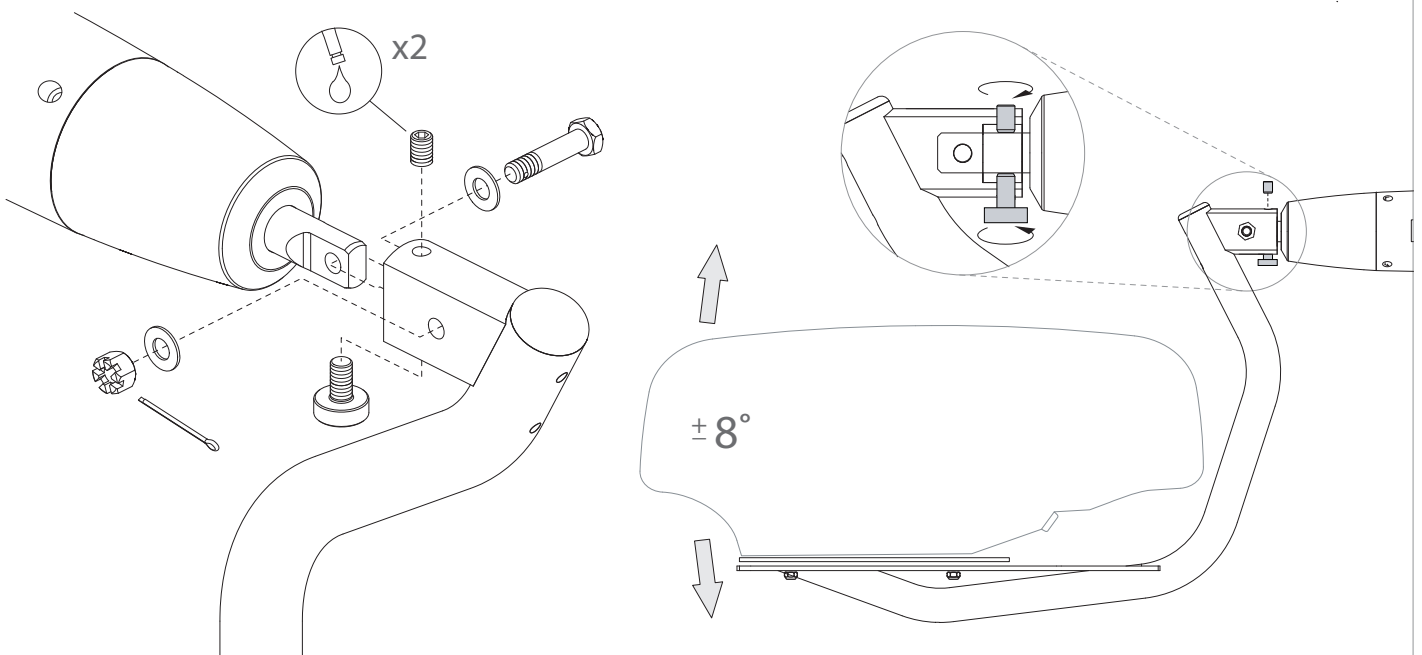

11A

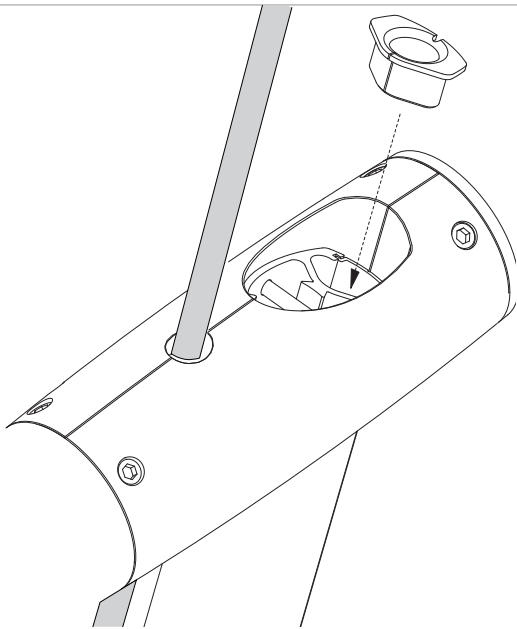

11B

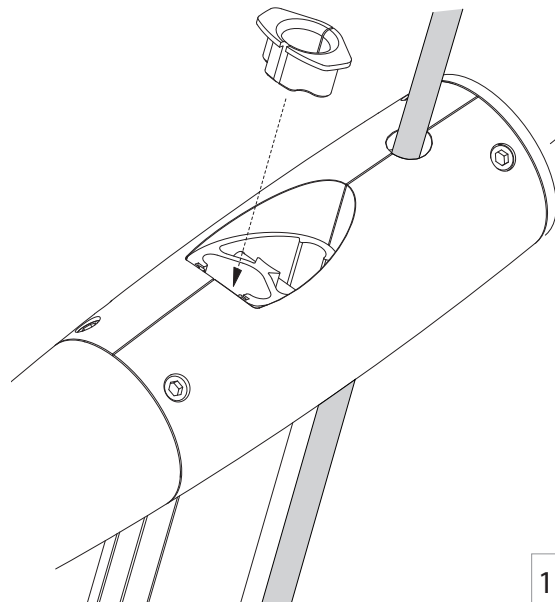

12

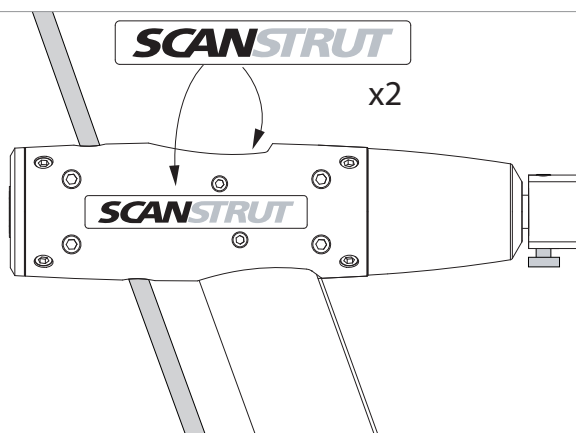
**IMPORTANT**

LMB-F1/A1 and LMB-F2/A2 are intended to mount a single radome as stated in the latest Scanstrut Product Guide – subject to change without prior notice. A GPS antenna can be installed using part LM-GPS.

Use of the LMB-F1/A1 and LMB-F2/A2 with unapproved products, or overloading, invalidates any warranty.

No liability is accepted for damage caused by incorrect installation.

This product has been designed specifically for the mounting of approved radar (listed in the latest Scanstrut Product Guide.) under normal boating conditions.

This product is not designed to withstand overload, impact, excessive force or entanglement in sails and rigging.

The installation and assembly must be regularly inspected for evidence of damage or loose parts.

This product is designed to fit backstay cables from Ø7 [0.27"] to Ø14mm [0.55"].

For installations that differ from those stated here, please consult Scanstrut head office.

IMPORTANT

Les LMB-F1/A1 et LMB-F2/A2 sont conçus pour le montage d'un seul radôme comme mentionné dans le dernier Guide Produits Scanstrut – sujet à modification sans préavis. Une antenne GPS peut être installée à l'aide de l'article LM-GPS.

L'usage des LMB-F1/A1 et LMB-F2/A2 avec des produits non validés, ou la surcharge de ces supports, annulent toute garantie.

Scanstrut décline toute responsabilité pour les dégâts résultant d'une installation incorrecte.

Ce produit a été spécifiquement conçu pour le montage de radar approuvés (repris dans le Guide Produits Scanstrut) et utilisés dans des conditions de navigation normales.

Ce produit n'est pas conçu pour supporter une surcharge, un impact, une force excessive ou un enchevêtrement dans les voiles et le gréement.

L'installation et l'assemblage doivent être inspectés régulièrement afin de détecter des dégâts ou des pièces desserrées.

Ce produit est conçu pour des câbles de pataras allant de [0.27"] à Ø14mm [0.55"].

Pour les installations différentes de celles reprises ici, veuillez contacter le siège social de Scanstrut.

WICHTIG

LMB-F1/A1 und LMB-F2/A2 sind für die Befestigung eines einzelnen Radoms vorgesehen, wie in der aktuellen Scanstrut Produktübersicht angegeben. Änderungen ohne vorherige Ankundigung vorbehalten. Eine GPS-Antenne kann mithilfe von Bauteil LM-GPS angebracht werden.

Durch Verwendung des LMB-F1/A1 und LMB-F2/A2 mit nicht genehmigten Produkten bzw. durch Überlastung wird jegliche Garantie ungültig.

Für Schäden aufgrund unsachgemäßen Einbaus wird keine Haftung übernommen.

Dieses Produkt wurde spezifisch für die Befestigung eines genehmigten Radars (in der Scanstrut Produktübersicht aufgeführt) und für den Einsatz unter normalen Bootfahrtsbedingungen entwickelt.

Dieses Produkt wurde nicht dafür ausgelegt, Überlastung, Stöße, übermäßige Krafteinwirkung oder Verwicklung in Segel und Takelage auszuhalten.

Der Anbau und die Baueinheit müssen regelmäßig auf Anzeichen von Schäden oder lockere Teile geprüft werden.

Dieses Produkt ist für die Montage an Achterstag-Seilen von Ø7 mm [0,27"] bis Ø14 mm [0,55"] ausgelegt.

Für andere Anbauten als die hier genannten wenden Sie sich bitte an die Scanstrut Zentrale.

IMPORTANTE

LMB-F1/A1 y LMB-F2/A2 están pensados para montar una antena radome según se establece en la última Guía de productos Scanstrut – sujeto a cambios sin previo aviso. También se puede montar una antena GPS usando el producto código LM-GPS.

El uso de los LMB-F1/A1 y LMB-F2/A2 con productos no aprobados, o bajo exceso de carga, invalidará cualquier garantía.

No se aceptará ninguna responsabilidad por los daños causados por una instalación incorrecta.

Este producto ha sido específicamente diseñado para el montaje de radares aprobados (listados en la Guía del Producto de Scanstrut) y debe utilizarse siempre bajo condiciones normales de navegación.

Este producto no está diseñado para soportar excesos de peso, impactos, fuerzas excesivas, ni debe tampoco enredarse entre las velas o aparejos.

La instalación y ensamblaje deberá inspeccionarse regularmente, comprobando cualquier evidencia de daños o piezas aflojadas.

Este producto está diseñado para instalarse en los cables del backstay, con un grosor entre Ø7 [0.27"] y Ø14mm [0.55"].

GPS

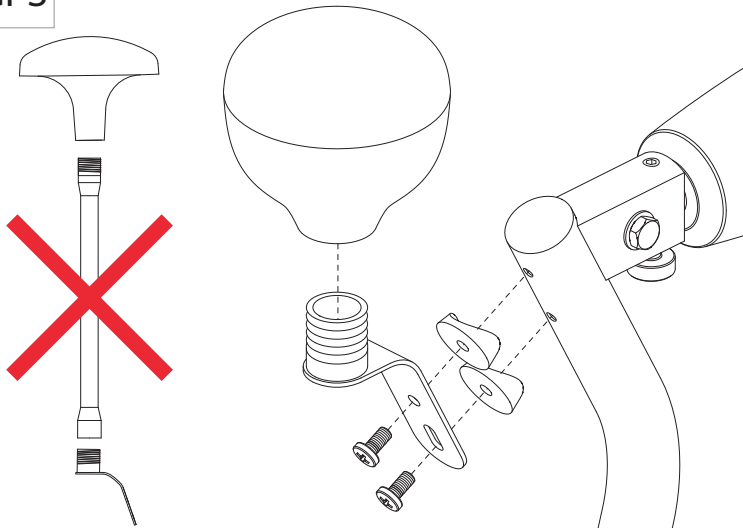
**IMPORTANTE**

LMB-F1/A1 e LMB-F2/A2 sono previsti per montare un solo radome come indicato nella più recente Guida ai Prodotti Scanstrut – fatte salve eventuali modifiche senza preavviso. Si può installare un'antenna GPS usando il pezzo LM-GPS.

L'uso di LMB-F1/A1 e LMB-F2/A2 con prodotti non approvati, o un loro sovraccarico, invalida qualsiasi garanzia. Si declina qualsiasi responsabilità per danni causati da un'installazione erranea.

Questo prodotto è stato studiato appositamente per il supporto di apparecchiature radar approvate (elencate nella Guida ai Prodotti Scanstrut) e utilizzate in normali condizioni di navigazione.

Questo prodotto non è progettato per resistere a sovraccarichi, urti, forze eccessive o l'ingarbugliamento in vele e sartie.

L'installazione e il montaggio devono essere ispezionati con regolarità per verificare la presenza di danni o di pezzi allentati.

Questo prodotto è stato studiato per essere montato su paterazzi di diametro compreso fra 7 e 14 mm.

Per installazioni diverse da quelle qui indicate, si prega di consultare la direzione centrale di Scanstrut.