

WISE

DELUXE FLIP-FLOP SEAT ASSEMBLY INSTRUCTIONS

8WD125FF PACKAGE CONTENTS

Back rest cushion, seat cushion, (2) aluminum arms, (2) side support brackets and mounting hardware

Base sold separately

Tools Required

Phillips head screw driver

Attach Flip-flop Arms to Back Rest

Take one square aluminum tube and locate the end with 2 bolt holes. Attach to either end of the back rest using (2) 2" screws. Repeat on the opposite side.

Attach Flip-flop Arms to Seat Base

Attach one arm bracket to the side of the base using (2) 1/2" screws. Repeat on opposite side.

Slide back rest arms through each mounted bracket.

Place (1) nylon bushing between the arm and base & attach (1) 1 1/2" screw through the arm and through the bushing into the base. Repeat on opposite side.

Attach Seat Cushion to Seat Base

There are (2) pre-mounted hinges on the seat cushion. Align each hinge with the notches on the seat base, and use the (6) 1/2" truss screws to secure both components.

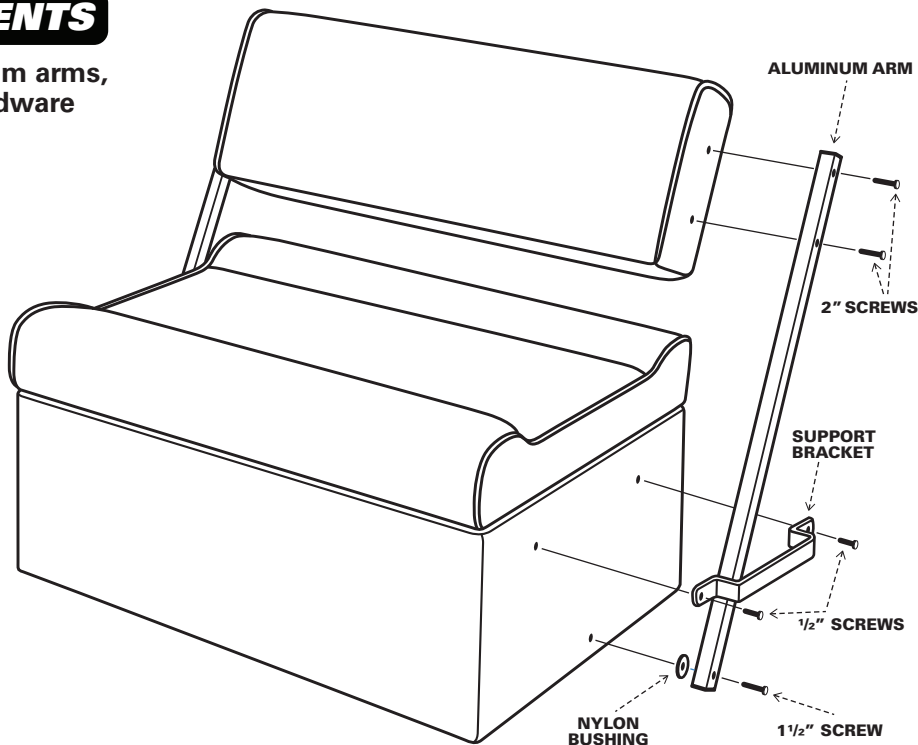

NOTE

TO AVOID CROSS-THREADING
OF FASTENERS PLEASE START
ALL SCREWS BY HAND

Questions? Missing Parts?
Please contact store from
which it was purchased

Above items are not manufactured
for commercial use.

WF11943